

Green-Mode PWM Controller with High Voltage Startup Circuit

Features

- High-Voltage (700V) Startup Circuit
- Very Low Startup Current (<30uA)
- Under-Voltage Lockout (UVLO)
- 50mW Standby Power
- Non-Audible-Noise Green-Mode Control
- 65KHz Switching Frequency with Jittering for Reducing EMI
- Cycle-by-Cycle Peak Current Limiting
- Internal Leading-Edge Blanking
- Internal Slope Compensation
- Gate Output Maximum Voltage Clamp
- Internal 6mS Soft Start
- Soft Driving for Reducing EMI
- AC Input Brownout Protection with Hysteresis
- Programmable Over Temperature Latch (OTP) Function
- Over-Voltage Protection (OVP) on VCC pin
- Over-Load Protection (OLP)
- Flexible Latch Shutdown Combination: OVP; OVP+OTP
- 500mA Driving Capability
- SOP-8 /SOP-7/DIP-8 Green Package

Applications

- Adaptor/ Open Frame Power Supply
- LCD Monitor/TV Power Supply

Description

The GR8875N series is a highly-integrated, low startup current, current mode PWM controller with green-mode function, high-voltage start up circuit, and provides several protections such as OLP, OVP, and OCP for fault conditions. A high-voltage current source supplies the start up current and the traditional start up resistance can be saved in order to reduce the start up power loss. The controller also includes the leading-edge blanking of the current sensing, internal slope compensation and cycle-by-cycle peak current limiting. It is also integrated soft driving for reducing EMI, gate output voltage clamp function for protecting power MOSFET.

Ordering and Marking Information

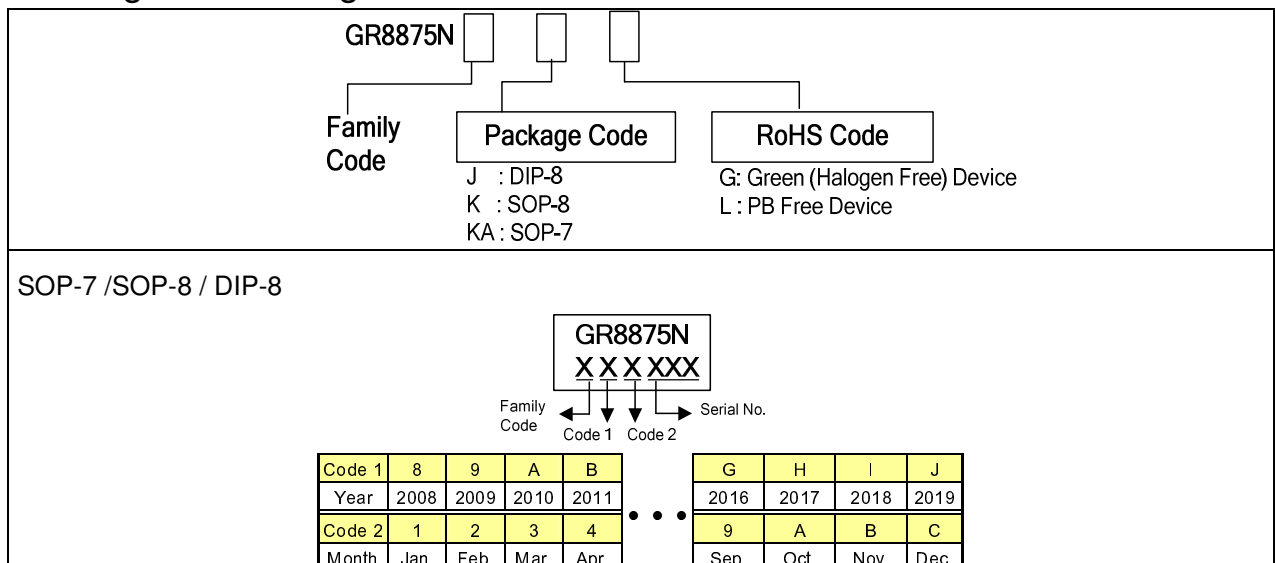

Greenergy OPTO Inc. reserves the right to make changes to improve reliability or manufacture ability without notice, and advise customers to obtain the latest version of relevant information to verify before placing orders.

Pin Description

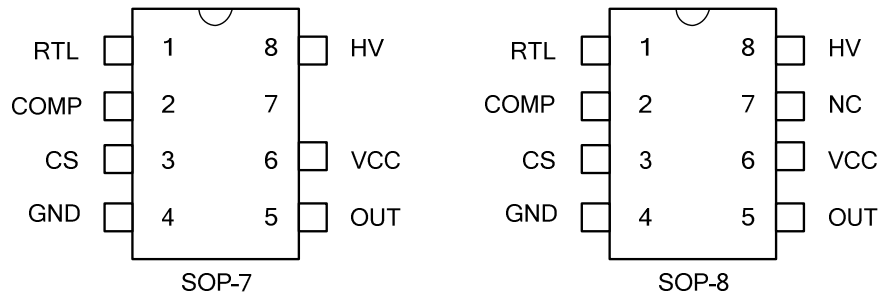

Pin	Symbol	Description
1	RTL	Latch trigger pin, which a high over 3.5V for OVP latch off and a low below 1.05V for OTP latch
2	COMP	Voltage feedback pin, by connecting a photo-coupler to control the duty cycle.
3	CS	Current sense pin, connect to sense the MOSFET current
4	GND	Ground
5	OUT	The output driver for driving the external MOSFET
6	VCC	Power supply pin
7	NC	Unconnected pin
8	HV	This pin provides the startup current. When UVLO (on) is tripped, this HV loop will be off and limit the power loss on the startup circuit.

Family Code	GR8875N	GR8875NL	GR8875NR	GR8875NH
Frequency	65KHz	65KHz	65KHz	100KHz
OLP/SCP	Auto-Recovery	Latch	Auto-Recovery	Auto-Recovery
VCC OVP	Latch	Latch	Auto-Recovery	Auto-Recovery
Latch Pin	Latch	Latch	Latch	Latch

Absolute Maximum Ratings

Supply Voltage VCC	-----	30V
High-Voltage Pin, HV	-----	- 0.3 ~ 500V
COMP, RTL, CS	-----	-0.3 ~ 7V
Junction Temperature	-----	150°C
Operating Ambient Temperature	-----	-40°C ~ 85°C
Storage Temperature Range	-----	-65°C ~ 150°C
SOP-8/SOP-7 Package Thermal Resistance	-----	160°C/W
DIP-8 Package Thermal Resistance	-----	100°C/W
Power Dissipation (SOP-8, at ambient temperature = 85°C)	-----	400 mW
Power Dissipation (DIP-8, at ambient temperature = 85°C)	-----	650mW
Lead Temperature (SOP-8 & DIP-8, soldering, 10sec)	-----	230°C
Lead Temperature (All Pb free packages, soldering, 10sec)	-----	260°C
ESD Voltage Protection, Human Body Model (Except HV pin)	-----	3KV
ESD Voltage Protection, Machine Model	-----	300V

Block Diagram

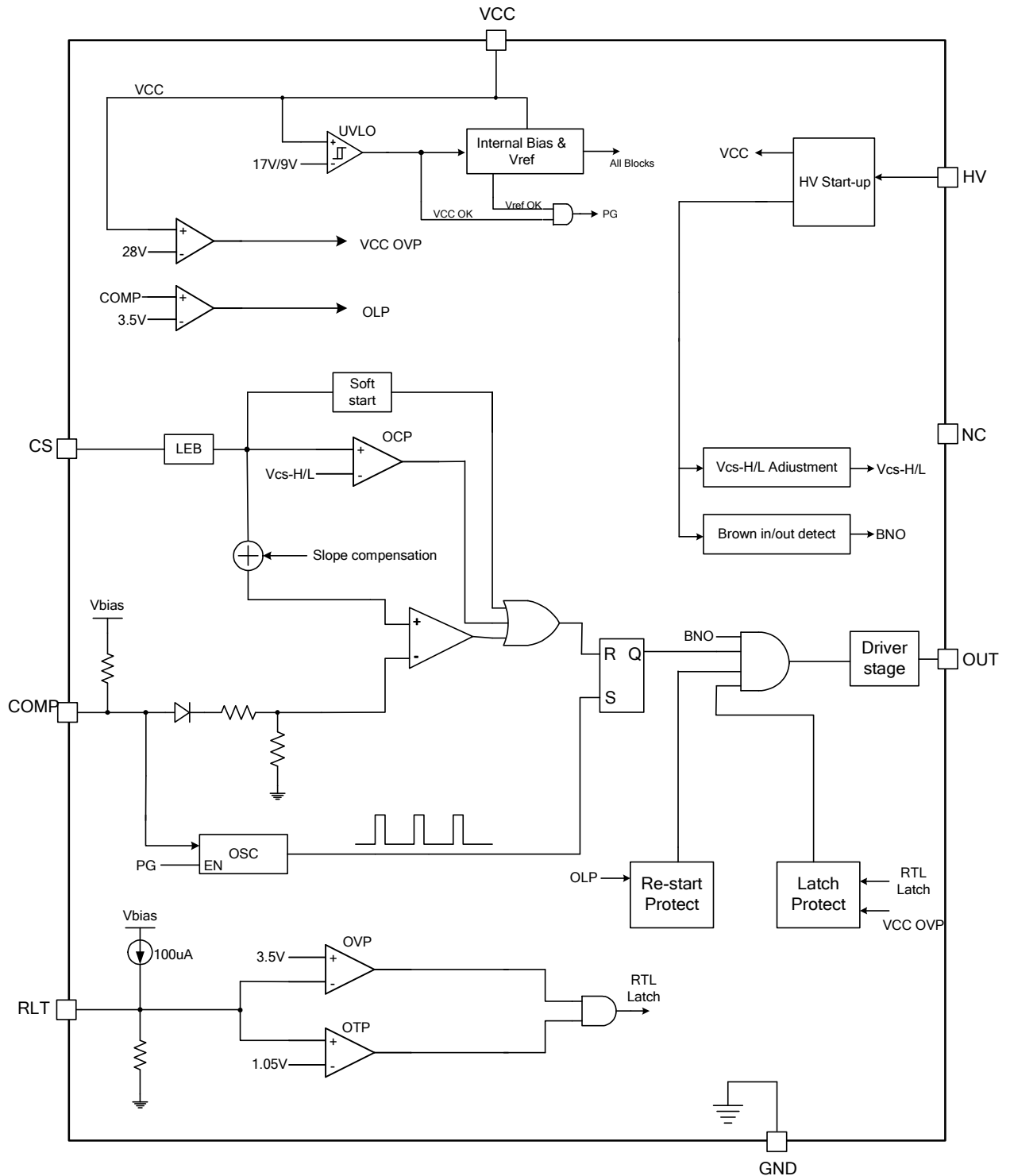



Electrical Characteristics (TA = + 25°C, VCC = 15.0V, unless otherwise specified)

Parameter	Pin	Min	Typ	Max	Unit
-----------	-----	-----	-----	-----	------

HIGH-VOLTAGE SUPPLY (HV Pin)

High-Voltage Current Source (V _{DC} =370 ,R=125k V _{CC} = 0V)	8		2.96	4	mA
Off-State Leakage Current	8			36	uA
Brownout Threshold (see below equation 1) DC source R=125KΩ		92	102	112	V
Brownin Threshold (see below equation 2) DC source R=125KΩ		104	114	124	V
PWM Turn-Off Debounce Time- Normal Operation			75		mS

SUPPLY VOLTAGE

Startup Current	6			30	uA
Operating Current (with 1nF load on OUT pin), V _{comp} = 0V	6		0.8		mA
Operating Current (with 1nF load on OUT pin), V _{comp} = 2.5V	6		2.2		mA
Operating Current (with 1nF load on OUT pin), Protection Tripped (OLP, OVP)	6		0.5		mA
UVLO (off)	6	8	9	10	V
UVLO (on)	6	16	17	18	V
OVP on VCC Pin	6	27	28	29	V

VOLTAGE FEEDBACK

Open Loop Voltage, Comp Pin Open	2		4.5		V
Delay Time of Comp Pin Open Loop Protection	2		50		mS

CURRENT SENSING

Current Limit @ Low Line(V _{ac} =86V) V _{DC} =122 Series R _{HV} =125k to HV V _{cs} -H	3	0.80	0.85	0.90	V
Current limit @ High Line(V _{ac} =259V)V _{DC} =366 Series R _{HV} =125k to HV V _{cs} -L	3		0.7		V
Leading-Edge Blanking Time without T _{pd}	3		250		nS
Input Impedance	3	1			mΩ
Delay to Output	3		100		nS

OSCILLATOR

Frequency	Normal PWM Frequency		60	65	70	KHz
	Jitter Range			±6%		KHz
Green Mode Frequency				22		KHz
Temp. Stability (-40°C ~ 105°C)					5	%
Voltage Stability (VCC = 11V ~ 25V)					2	%

GATE DRIVER OUTPUT

Output Low Level, VCC = 15V, I _O = 20mA	5			1	V
Output High Level, VCC = 15V, I _O =20mA	5	8			V



Rising Time, Load Capacitance = 1000pF	5		150		nS
Falling Time, Load Capacitance = 1000pF	5		50		nS
VGATE-Clamp (VCC = 25V)	5	11	13	15	V

PWM SECTION

Maximum Duty Cycle		70	75	80	%
Soft Start Time (Freq=65kHz)			6		mS

***Latch PIN FUNCTION OPTION (See below Fig.1)**

Over Voltage Protection Threshold Voltage	3	3.2	3.5	3.8	V
OVP Debounce, Fs = 65kHz	3		100		uS
Over Temperature Protection Threshold Voltage	3	0.95	1.05	1.15	V
OTP Debounce, Fs = 65kHz	3		100		uS
Output Current from RTL Pin	3	92	100	108	uA
Clamped Voltage	3		2.2		V
VCC De-latch Voltage			3.4		V

Below equations are for reference only.

Equation 1:
$$Vac - on(RMS) = \frac{[0.9v \times \frac{RHV + 1K}{1K}]}{\sqrt{2}}$$

Equation 2:
$$Vac - off(RMS) = \frac{[0.8v \times \frac{RHV + 1K}{1K}]}{\sqrt{2}}$$

Application Information

Overview

The GR8875N series integrates several functions that are needed in the market. It includes green-mode controller and high-voltage start-up circuit which can save the power loss after startup.

High-voltage Startup Circuit and Under-voltage Lockout (UVLO)

GR8875N series implements a high-voltage startup circuit, during the startup; high-voltage current sources are turned on and provide the start-up current as well as charge the Vcc capacitor. When the Vcc voltage is higher than the UVLO (on) threshold, the high-voltage current source will be turned off. Its leakage current is very low (30uA), which only consumes little power. By using such configuration, the traditional startup resistor is not needed and power consumption will reduce. (Refer to Fig. 1).

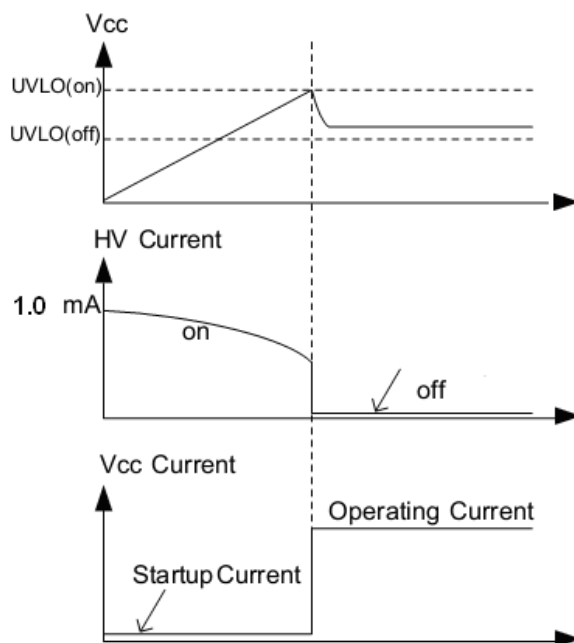

Fig. 1

A hysteresis UVLO comparator is implemented in GR8875N series, and then the turn-on and turn-off threshold levels are fixed at 17V and 9V

respectively. This hysteresis shown in Fig.1 ensures that the start-up capacitor will be adequate to supply the chip during start-up.

Oscillator

The maximum duty-cycle of internal oscillator is limited to about 75% to avoid the transformer saturation.

Green-mode Operation

When the load decreases to an extent, the frequency of the controller will decrease so as to reduce the system power consumption. The minimum frequency is about 22 KHz which is outside the audio range.

Leading-edge Blanking (LEB)

Each time the power MOSFET is switched on, a turn-on spike will inevitably occur at the sensor resistor. To avoid fault trigger, a 250ns leading-edge blanking time is built in. Conventional RC filtering can therefore be omitted. During this blanking period, the current-limit comparator is disabled and cannot switch off the gate driver.

Internal Slope Compensation

A built-in slope compensation circuit is constructed in GR8875N series. When the switch is on, a ramp voltage is added to the sensed voltage across the CS pin, which helps to stabilize the system and prevent sub-harmonic oscillations.

Gate Clamp/Soft Driving

Driver is clamped by an internal 13V Zener diode. Those damages usually come from undesired over-voltage gate signals. Under the conditions listed below, the gate output will turn off immediately to protect the power circuit. The GR8875N series also has soft driving function to minimize EMI.

Soft Start

During initial power on, the GR8875N series provides soft start function. It effectively suppresses the start up peak current to reduce the power MOSFET drain voltage especially at high line.

Over-load Protection (OLP)

The controller has an over load protection function. An internal circuit detects the Comp pin level, when the level is larger than a threshold and the condition lasts more than 50mS, then the gate output will keep low level. The VCC will decrease to UVLO off level and the controller will be reset again. Fig.2 shows the waveform of the OLP operation.

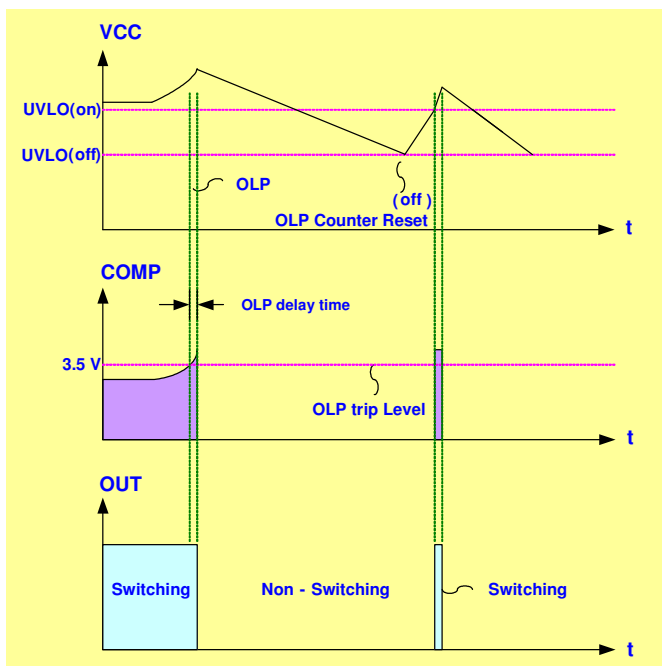

Fig. 2

Over-voltage Protection on VCC-Latch Mode

To prevent power MOSFET from being damaged, the GR8875N series is implemented an OVP function on VCC. When the VCC voltage is higher than the OVP threshold voltage, the output gate driver circuit will be shut down immediately to stop the switching of power MOSFET. The VCC pin

OVP function is a latch type protection. GR8875N series is working in latch mode as shown in Fig. 3.

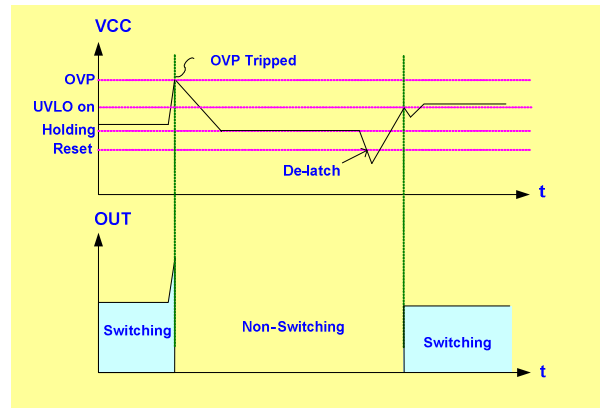

Fig. 3

Brown-in/Brown-out and Constant Power Limited by HV pin

Unlike previous PWM controllers, the HV pin of GR8875N series isn't only used for startup; it can also detect the AC line voltage to perform brown-in/brown-out function and set the high low line constant power compensation. Equations 1 and 2 can be used to calculate out the level of brown-in and brown-out converted to RMS value.

RTL Pin Latch Off Mode

The typical application for RTL pin is shown in Fig.4. The Zener diode is setting as external OVP protection and the NTC thermistor is setting as external OTP protection. In the RTL pin, there are two comparators for latch-off mode protection. While the voltage on this pin is higher than 3.5V or lower than 1.05V, the GR8875N series will shut down after the de-bounce time 100uS. And the GR8875N series will never auto recovery, unless the VCC pin voltage is down to reset level as same as shown in Fig. 3

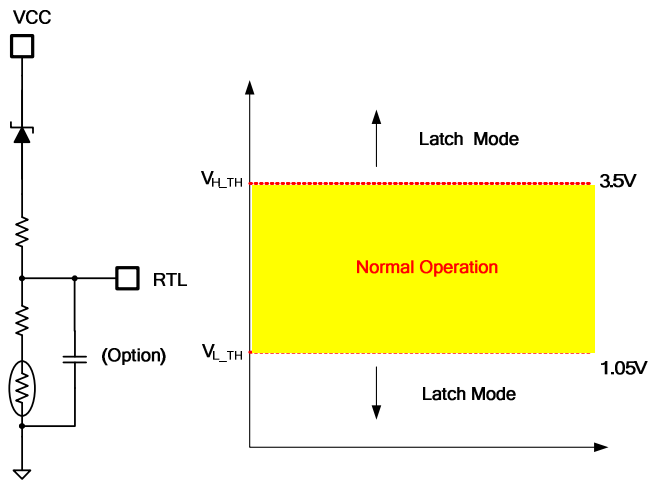
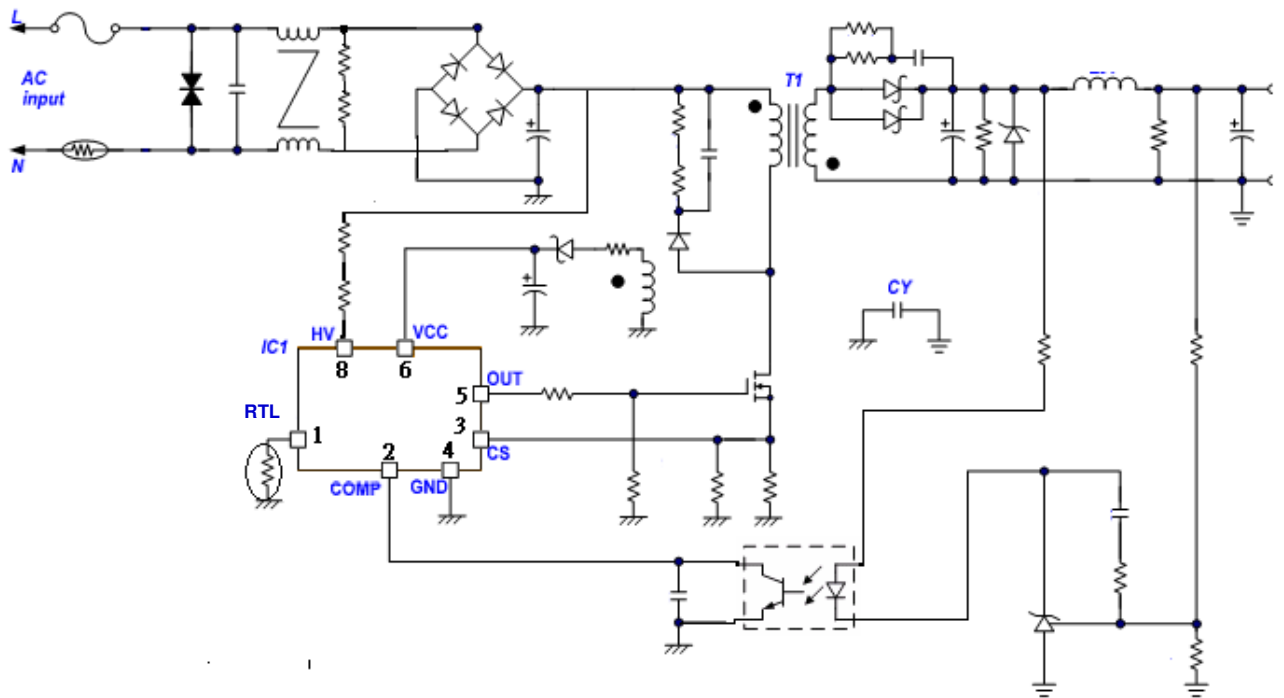

Fig.4

Application Circuit





Package Information

SOP-8

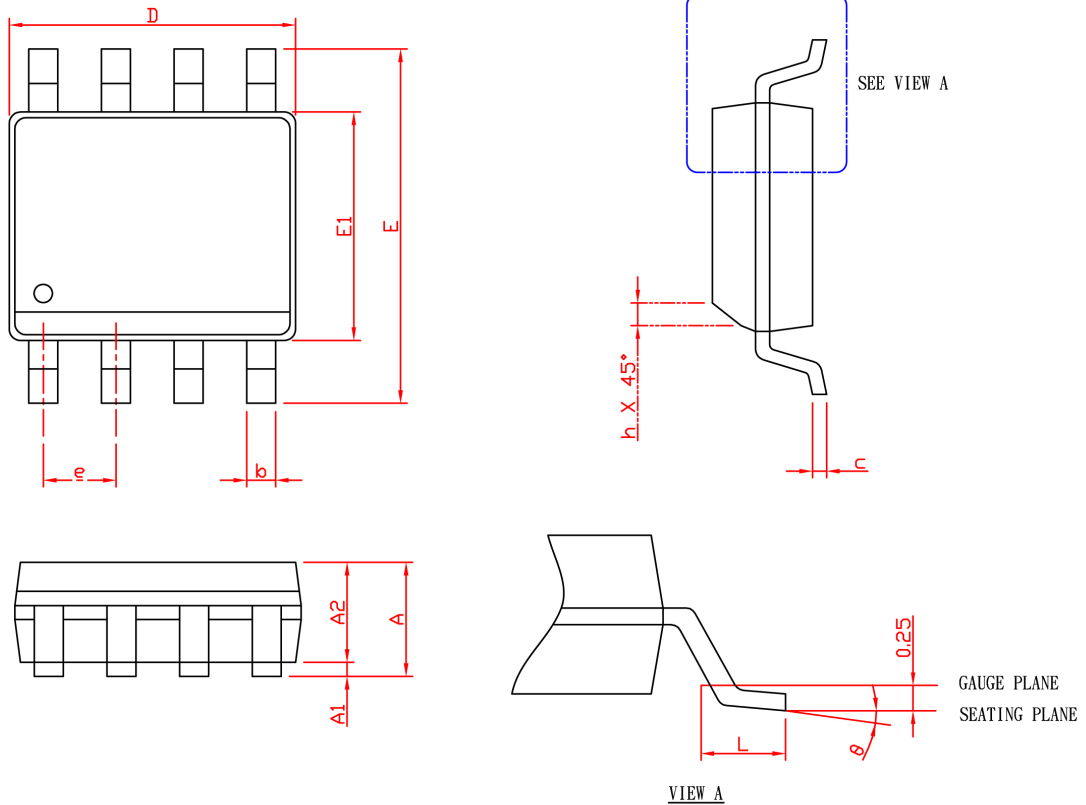

SYMBOL	SOP-8			
	MILLIMETERS		INCHES	
	MIN.	MAX.	MIN.	MAX.
A		1.75		0.069
A1	0.10	0.25	0.004	0.010
A2	1.25		0.049	
b	0.31	0.51	0.012	0.020
c	0.17	0.25	0.007	0.010
D	4.80	5.00	0.189	0.197
E	5.80	6.20	0.228	0.244
E1	3.80	4.00	0.150	0.157
e	1.27 BSC		0.050 BSC	
h	0.25	0.50	0.010	0.020
L	0.40	1.27	0.016	0.050
θ	0°	8°	0°	8°

Note: 1. Followed from JEDEC MS-012 AA.

2. Dimension "D" does not include mold flash, protrusions or gate burrs. Mold flash, protrusion or gate burrs shall not exceed 6 mil per side.

3. Dimension "E1" does not include inter-lead flash or protrusions. Inter-lead flash and protrusions shall not exceed 10 mil per side.

Package Information

SOP-7

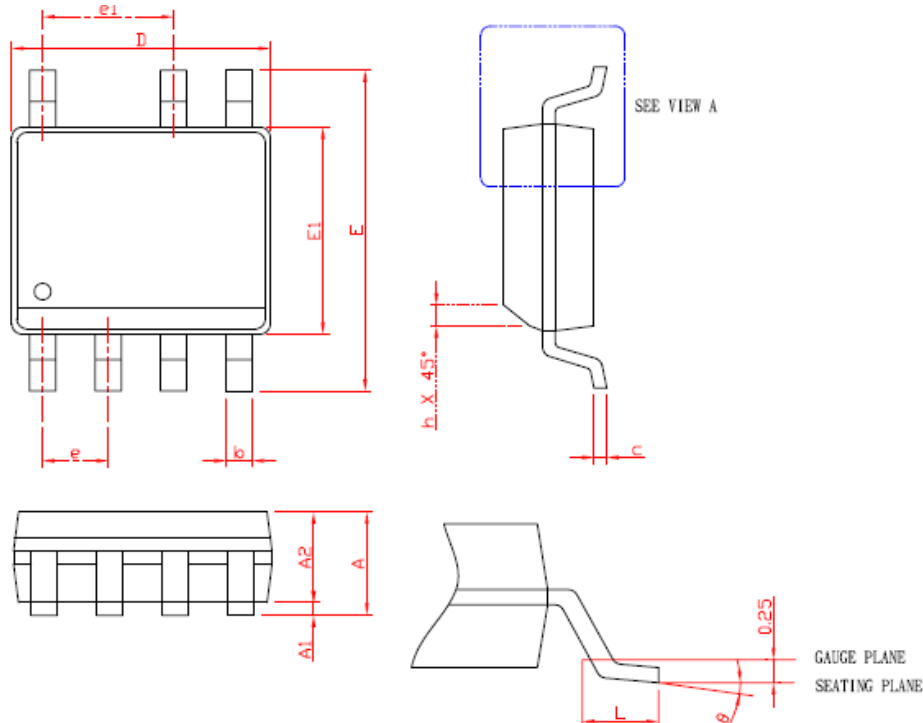

SYMBOL	SOP-7			
	MILLIMETERS		INCHES	
	MIN.	MAX.	MIN.	MAX.
A		1.75		0.069
A1	0.10	0.25	0.004	0.010
A2	1.25		0.049	
b	0.31	0.51	0.012	0.020
c	0.17	0.25	0.007	0.010
D	4.80	5.00	0.189	0.197
E	5.80	6.20	0.228	0.244
E1	3.80	4.00	0.150	0.157
e	1.27 BSC		0.050 BSC	
e1	2.54 BSC		0.101 BSC	
h	0.25	0.50	0.010	0.020
L	0.40	1.27	0.016	0.050
θ	0°	8°	0°	8°

Note: 1. Dimension "D" does not include mold flash, protrusions or gate burrs. Mold flash, protrusion or gate burrs shall not exceed 6 mil per side.

2. Dimension "E" does not include inter-lead flash or protrusions. Inter-lead flash and protrusions shall not exceed 10 mil per side.

Package Information

DIP-8

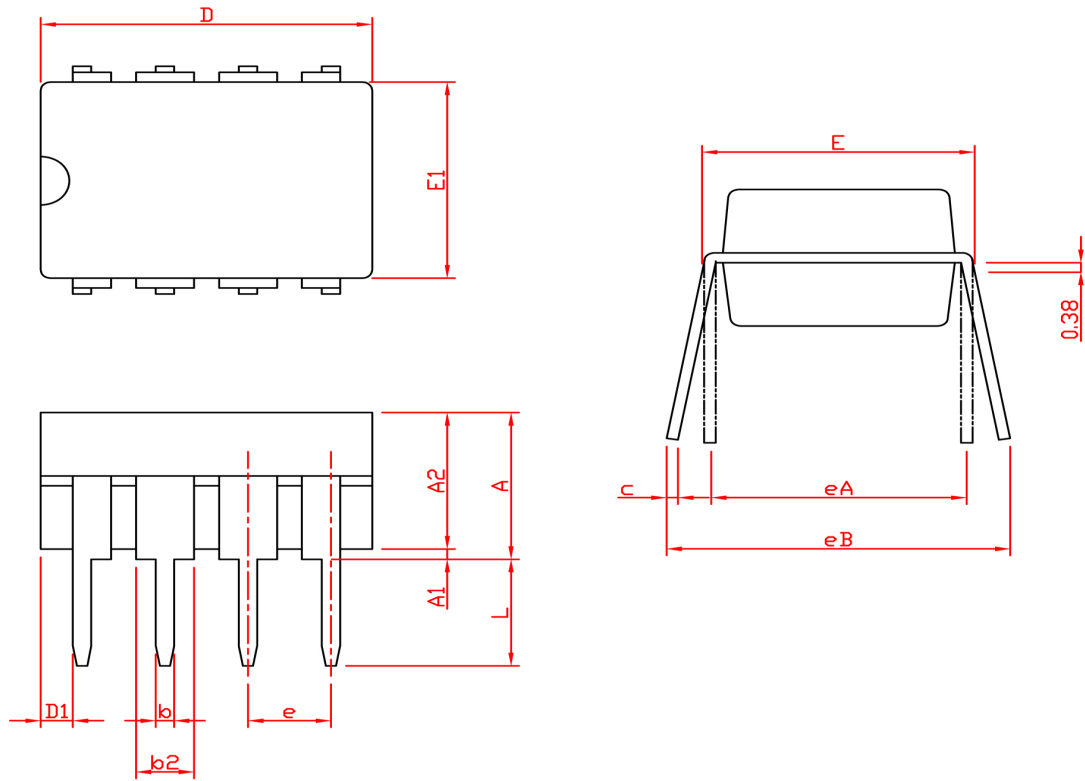

SYMBOL	DIP-8			
	MILLIMETERS		INCHES	
	MIN.	MAX.	MIN.	MAX.
A		5.33		0.210
A1	0.38		0.015	
A2	2.92	4.95	0.115	0.195
b	0.36	0.56	0.014	0.022
b2	1.14	1.78	0.045	0.070
c	0.20	0.35	0.008	0.014
D	9.01	10.16	0.355	0.400
D1	0.13		0.005	
E	7.62	8.26	0.300	0.325
E1	6.10	7.11	0.240	0.280
e	2.54 BSC		0.100 BSC	
eA	7.62 BSC		0.300 BSC	
eB		10.92		0.430
L	2.92	3.81	0.115	0.150

Note: 1. Followed from JEDEC MS-001 BA.

2. Dimension D, D1 and E1 do not include mold flash or protrusions. Mold flash or protrusions shall not exceed 10 mil.



Carrier Tape & Reel Dimensions

SOP- 8/SOP-7

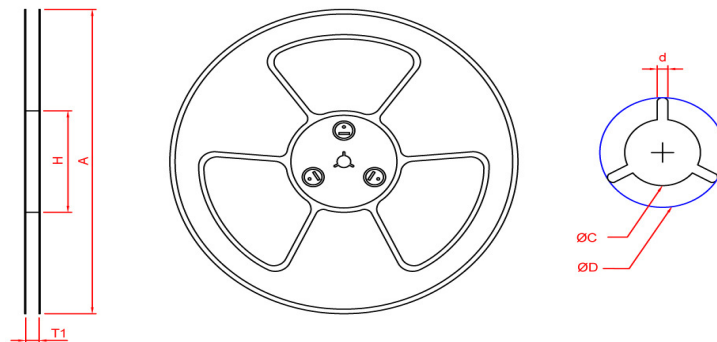
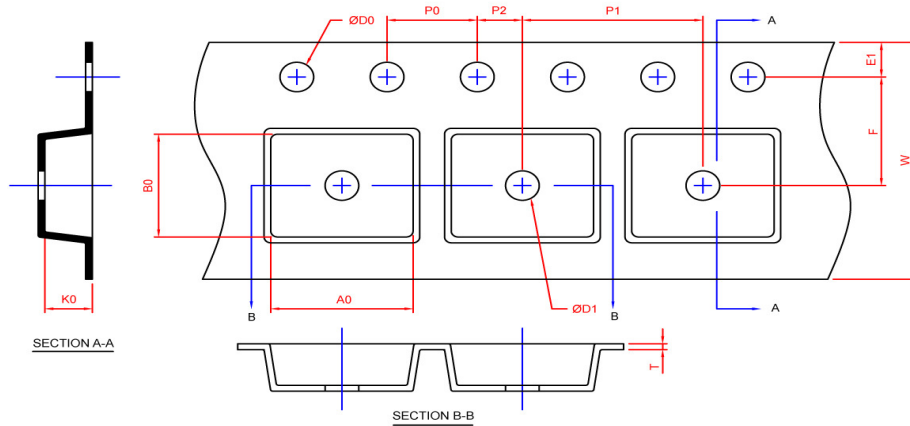

Application	A	H	T1	C	d	D	W	E1	F
SOP-8/SOP7	330.0±2.0	50 MIN.	12.4+2.00 -0.00	13.0+0.50 -0.20	1.5 MIN.	20.2 MIN.	12.0±0.30	1.75±0.10	5.5±0.05
	P0	P1	P2	D0	D1	T	A0	B0	K0
	4.0±0.10	8.0±0.10	2.0±0.05	1.5+0.10 -0.00	1.5 MIN.	0.6+0.00 -0.40	6.40±0.20	5.20±0.20	2.10±0.20

(mm)

Devices Per Unit

Application	Carrier Width	Cover Tape Width	Devices Per Reel
SOP- 8/SOP-7	12	-	2500



Taping Direction Information

SOP-8/ SOP-7



Greenergy OPTO, Inc. reserves the right to make corrections, modifications, enhancements, improvements, and other changes to its products and services at any time and to discontinue any product or service without notice. Customers should obtain the latest relevant information before placing orders and should verify that such information is current and complete.